

Swing Check Valve

## SICCA 150-600 SCC

Class 150-600  
NPS 2-24 Inches

### Type Series Booklet



## **Legal information/Copyright**

Type Series Booklet SICCA 150-600 SCC

All rights reserved. The contents provided herein must neither be distributed, copied, reproduced, edited or processed for any other purpose, nor otherwise transmitted, published or made available to a third party without the manufacturer's express written consent.

Subject to technical modification without prior notice.

© KSB Aktiengesellschaft, Frankenthal 13/12/2017

---

## Contents

<b>Check Valves and Strainers .....</b>	<b>4</b>
Swing Check Valves to ANSI/ASME .....	4
SICCA 150-600 SCC .....	4
Main applications.....	4
Fluids handled .....	4
Operating data.....	4
Body materials.....	4
Design details .....	4
Product benefits.....	5
Related documents .....	5
Purchase order specifications .....	5
Pressure/temperature ratings.....	6
Materials.....	7
Dimensions and weights.....	8
Notes on installation.....	9

## Check Valves and Strainers

### Swing Check Valves to ANSI/ASME

## SICCA 150-600 SCC



#### Main applications

- Mining
- Chemical industry
- Descaling units
- Domestic water supply
- Boiler feed applications
- Boiler recirculation
- Fossil-fuelled power stations
- Cooling circuits
- Pulp and paper industry
- Petrochemical industry
- Pharmaceutical industry
- Pipelines and tank farms
- Refineries
- Rainwater harvesting
- Process engineering
- Heat recovery systems
- Hot-water heating systems
- Water extraction
- Water supply systems
- Sugar industry

#### Fluids handled

- Service water
- Steam
- Fluids containing gas
- Gas
- High-temperature hot water
- Heating water

- Condensate
- Cooling water
- Fire-fighting water
- Volatile fluids
- Fluids containing mineral oils
- Oil
- Lubricants
- Grey water
- Feed water
- Thermal oil
- Wash water

#### Operating data

Operating properties

Characteristic	Value
Nominal pressure	Class 150 - 600
Nominal size [inch]	NPS 2 - 24
Max. permissible pressure [bar]	103
Max. permissible pressure [psi]	1500
Min. permissible temperature [°C]	≥ 0
Max. permissible temperature [°C]	≤ +593
Min. permissible temperature [°F]	≥ 0
Max. permissible temperature [°F]	≤ +1100

Selection as per pressure/temperature ratings (⇒ Page 6)

#### Body materials

Overview of available materials

Material	Temperature limit	
	[°C]	[°F]
ASTM A216 WCB	≤ 425	≤ 800
ASTM A217 WC6	≤ 593	≤ 1100
ASTM A351 CF8	≤ 537	≤ 1000
ASTM A351 CF8M	≤ 537	≤ 1000

#### Design details

##### Design

- Swing check valve to BS 1868
- Design to API 594 (type B)
- Cast steel body
- Hard-faced seat/disc interface (13 % chrome steel/Stellite)
- Bolted bonnet
- Outside confined cover gasket
- Seat ring welded into body
- Internally mounted hinge pin up to 12 inch
- Self-aligning free-floating and non-rotating valve disc
- Flanged ends
- Butt weld ends
- The valves satisfy the safety requirements of Annex I of the European Pressure Equipment Directive 2014/68/EU (PED) for fluids in Groups 1 and 2.
- The valves meet the requirements of the Indian Boiler Regulations 1950.

**Variants**

- Drain plug
- Drain branch
- Bypass
- Dash pot arrangement for nominal sizes from NPS 14 in.
- Special Class version for model with butt weld ends

**Product benefits**

- Additional features ensure safe sealing to atmosphere:
  - Risk of leakage is reduced by internally mounted hinge pin.
  - Fully confined cover gasket with controlled compression ensures leak-proof joint.
- Reliable, tight shut-off
  - Hard-faced body seat made of wear-resistant and corrosion-resistant 13 % chrome steel or Stellite.
  - High-grade surface finish: lapped seat/disc interface
  - Self-aligning valve disc ensures tight shut-off.
  - Valve disc opens at low differential pressure.
- Economic benefits
  - Streamlined flow path minimises pressure losses.

**Related documents**

Information/documents

Document	Reference number
Type series booklet	7243.1
SICCA 900-3600 SCC	
Operating manual	0500.80

**Purchase order specifications**

Please specify the following information in all enquiries or purchase orders:

1. Type
2. Class
3. Nominal size
4. Design pressure
5. Design temperature
6. Operating pressure
7. Operating temperature
8. Differential pressure
9. Material
10. Fluid handled
11. Flow rate
12. Pipe connection
13. Pipe schedule
14. Variants
15. Reference number

Always indicate the original serial number and the year of construction when ordering spare parts.

**Pressure/temperature ratings**

Permissible operating pressures [bar] (in acc. with ASME B16.34 Standard Class)

Class	Material	[°C]																							
		-29 to +38	93	149	204	260	316	343	371	399	427	454	482	510	538	566	593	621	649	677	704	732	760	788	816
150	A216 WCB <sup>1)</sup>	20	18	16	14	12	10	9	8	7	6	5	3	2	1	-	-	-	-	-	-	-	-	-	-
300		51	47	45	44	42	39	38	37	35	28	22	16	9	6	-	-	-	-	-	-	-	-	-	-
600		102	94	90	87	83	78	76	73	70	57	44	32	19	12	-	-	-	-	-	-	-	-	-	-
150	A217 WC6 <sup>2)3)</sup>	20	18	16	14	12	10	9	8	7	6	5	3	2	1	1	1	1	1	1	1	1	1	1	1
300		52	52	50	48	46	42	41	39	37	35	33	31	22	15	10	7	5	3	-	-	-	-	-	
600		103	103	100	96	92	83	81	78	73	70	67	62	44	30	20	13	9	6	-	-	-	-	-	-
150	A351 CF8 <sup>4)</sup>	19	16	14	13	12	10	9	8	7	6	5	3	2	1	1	1	1	1	1	1	1	1	1	1
300		50	41	37	34	32	30	30	29	29	28	27	27	26	25	22	18	14	11	9	8	7	5	4	3
600		99	83	74	69	64	61	60	58	57	56	55	54	53	49	45	36	28	23	18	16	13	10	8	6
150	A351 CF8M <sup>4)</sup>	19	16	15	13	12	10	9	8	7	6	5	3	2	1	1	1	1	1	1	1	1	1	1	1
300		50	43	39	36	33	31	30	30	29	29	29	29	27	25	25	21	16	13	10	8	7	5	4	3
600		99	86	77	71	66	62	61	60	59	58	58	57	53	50	50	42	33	26	20	16	13	10	8	6

Permissible operating pressures [psi] (in acc. with ASME B16.34 Standard Class)

Class	Material	[°F]																							
		-20 to +100	200	300	400	500	600	650	700	750	800	850	900	950	1000	1050	1100	1150	1200	1250	1300	1350	1400	1450	1500
150	A216 WCB <sup>1)</sup>	285	260	230	200	170	140	125	110	95	80	65	50	35	20	-	-	-	-	-	-	-	-	-	-
300		740	680	655	635	605	570	550	530	505	410	320	230	135	85	-	-	-	-	-	-	-	-	-	-
600		1480	1360	1310	1265	1205	1135	1100	1060	1015	825	640	460	275	170	-	-	-	-	-	-	-	-	-	-
150	A217 WC6 <sup>2)3)</sup>	290	260	230	200	170	140	125	110	95	80	65	50	35	20	20	20	20	15	-	-	-	-	-	-
300		750	750	720	695	665	605	590	570	530	510	485	450	320	215	145	95	65	40	-	-	-	-	-	
600		1500	1500	1445	1385	1330	1210	1175	1135	1065	1015	975	900	640	430	290	190	130	80	-	-	-	-	-	-
150	A351 CF8 <sup>4)</sup>	275	230	205	190	170	140	125	110	95	80	65	50	35	20	20	20	20	20	20	20	20	20	20	15
300		720	600	540	495	465	440	430	420	415	405	395	390	380	355	325	255	205	165	135	115	95	75	60	40
600		1440	1200	1075	995	930	885	865	845	825	810	790	780	765	710	650	515	410	330	265	225	185	150	115	85
150	A351 CF8M <sup>4)</sup>	275	235	215	195	170	140	125	110	95	80	65	50	35	20	20	20	20	20	20	20	20	20	20	15
300		720	620	560	515	480	450	440	435	425	420	420	415	385	365	360	305	235	185	145	115	95	75	60	40
600		1440	1240	1120	1025	955	900	885	870	855	845	835	830	775	725	720	610	475	370	295	235	190	150	115	85

**Test pressure**

Test	Test medium	Class 150	Class 300	Class 600
		[bar]	[bar]	[bar]
Shell	Water	31	78	157
Leak test (seat)		22	57	114

- 1) Permissible but not recommended for prolonged use above 427 °C.
- 2) Use normalised and tempered materials only.
- 3) Cannot be used for temperatures above 593 °C
- 4) At temperatures over 538 °C, use only when carbon content is 0.04% or higher.

Materials

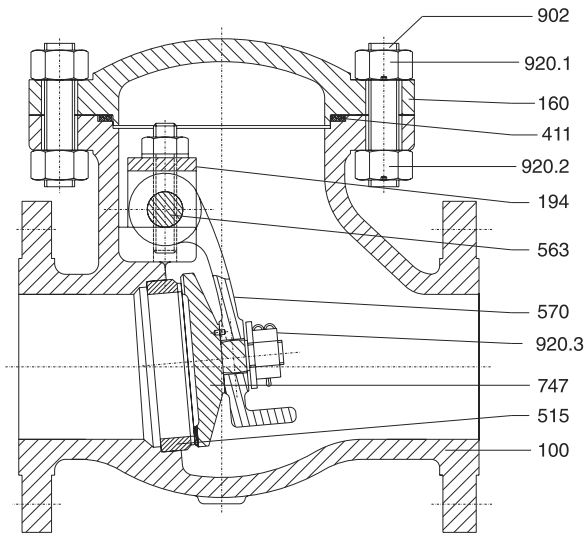

SICCA 150-600 SCC

Parts list

Part No.	Description	Material
100	Body	A216 WCB
		A217 WC6
		A351 CF8
		A351 CF8M
160	Cover	A216 WCB
		A217 WC6
		A351 CF8
		A351 CF8M
411	Gasket	SS 316 + graphite
515	Seat ring	A105+ST6
		A182 F11+ST6
		A182 F304
		A182 F316
563	Hinge pin	A479 410-2
		A276 304
		A276 316
570	Hanger arm	A216 WCB
		A217 WC6
		A351 CF8
		A351 CF8M
747	Valve disc	A105+13 % chrome/A216 WCB+13 % chrome
		A217 WC6+ST6
		A182 F304
		A182 F316
902	Stud	A193 B7
		A193 B16
		A193 B8
		A193 B8M
920.1	Nut	A194 2H
		A194 4/7
		A194 B8
		A194 8M
920.2	Nut	A194 2H
		A194 4/7
		A194 B8
		A194 8M
920.3	Nut	SS (18-8) / A194 2H
		SS (18-8) / A194 4/7
		SS (18-8)
		A194 8M

Dimensions and weights

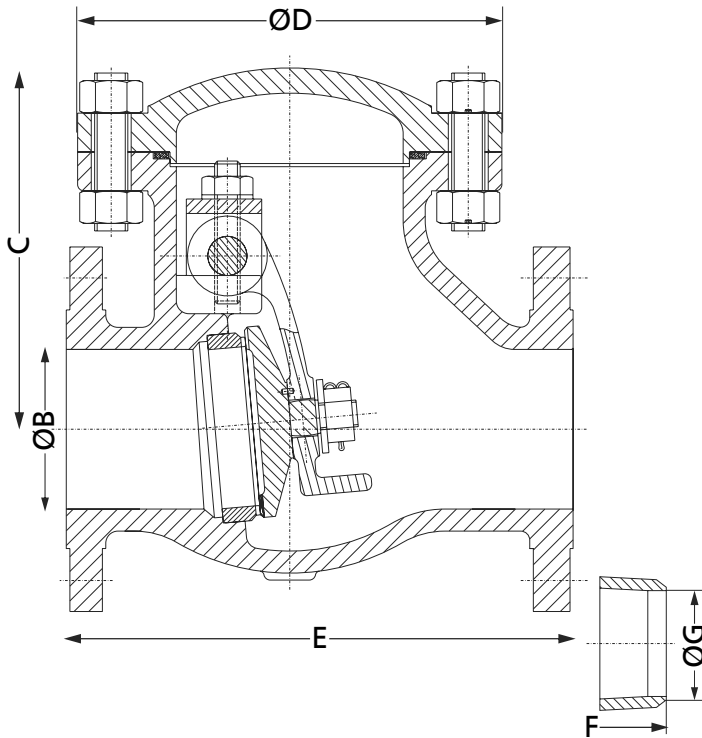

Dimensions and weights

Class	NPS	ØB	C <sup>5)6)</sup>	ØD	E	F <sup>7)</sup>	ØG <sup>7)</sup>	With flanged ends	With butt weld ends
	[inch]	[mm]	[mm]	[mm]	[mm]	[mm]	[mm]	[kg] <sup>6)</sup>	[kg] <sup>6)</sup>
150	2	51,0	160,0	□145	203,2	203,2	52,5	16,0	11,0
	2 1/2	63,5	157,0	□145	216,0	216,0	62,5	18,0	13,5
	3	76,0	200,0	210,0	241,3	241,3	78,0	35,0	32,0
	4	102,0	230,0	235,0	292,1	292,1	102,0	47,0	42,0
	5	127,0	203,0	259,0	356,0	356,0	128,0	50,0	40,0
	6	152,0	250,0	305,0	355,6	355,6	154,0	80,0	65,0
	8	203,0	310,0	350,0	495,3	495,3	203,0	125,0	105,0
	10	254,0	380,0	435,0	622,3	622,3	254,5	220,0	190,0
	12	305,0	420,0	474,0	698,5	698,5	303,0	345,0	300,0
	14	336,0	500,0	536,0	787,4	787,4	333,5	440,0	415,0
	16	387,0	555,0	605,0	863,6	863,6	381,0	590,0	555,0
	18	438,0	610,0	680,0	977,9	977,9	428,5	765,0	730,0
	20	489,0	655,0	750,0	977,9	977,9	478,0	955,0	910,0
24	591,0	740,0	870,0	1295,4	1295,4	574,5	1410,0	1340,0	
300	2	51,0	155,0	□145	266,7	266,7	52,5	22,0	17,0
	2 1/2	63,5	166,0	200,0	292,0	292,0	62,5	30,0	20,0
	3	76,0	210,0	210,0	317,5	317,5	78,0	41,0	36,0
	4	102,0	240,0	245,0	355,6	355,6	102,0	63,0	48,0
	5	127,0	220,0	287,0	400,0	400,0	128,0	80,0	60,0
	6	152,0	280,0	305,0	444,5	444,5	154,0	120,0	100,0
	8	203,0	330,0	370,0	533,4	533,4	203,0	265,0	225,0
	10	254,0	385,0	435,0	622,3	622,3	254,5	280,0	235,0
	12	305,0	445,0	474,0	711,2	711,2	303,0	390,0	350,0
14	337,0	560,0	580,0	838,2	838,2	333,5	680,0	620,0	
16	387,0	640,0	650,0	863,6	863,6	381,0	890,0	815,0	
600	2	51,0	190,0	187,0	292,1	292,1	49,2	28,0	23,0
	3	76,0	230,0	224,0	355,6	355,6	73,5	55,0	47,0
	4	102,0	260,0	280,0	431,8	431,8	97,0	97,0	70,0
	6	152,0	300,0	340,0	558,8	558,8	146,5	160,0	130,0

5) Open

6) Approximate values

7) Valves with butt weld ends: Schedule 40 for Class 150/300 and Schedule 80 for Class 600. Alternative schedules on request.



Class	NPS	ØB	C <sup>5)6)</sup>	ØD	E	F <sup>7)</sup>	ØG <sup>7)</sup>	With flanged ends	With butt weld ends
	[inch]	[mm]	[mm]	[mm]	[mm]	[mm]	[mm]	[kg] <sup>6)</sup>	[kg] <sup>6)</sup>
600	8	200,0	395,0	422,0	660,4	660,4	193,5	310,0	235,0
	10	248,0	460,0	506,0	787,4	787,4	243,0	490,0	440,0
	12	298,0	560,0	560,0	838,2	838,2	289,0	640,0	575,0

**Mating dimensions as per standard**

Face-to-face lengths: ASME B16.10  
 Flanges: ASME B16.5  
 Butt weld ends: ASME B16.25

**Notes on installation**

The valve bodies are marked with an arrow indicating the flow direction.

Swing check valves must preferably be installed in horizontal pipes. When installing them in vertical pipes, make sure that the flow direction is upward, so that in the unpressurised condition, the disc will be closed by its own weight.







**KSB Pumps Limited**  
151, NSN Palayam Post  
Mettupalayam Road • Coimbatore - 641 031. (India)  
Tel. : +91 422 2468222  
Fax : +91 422 2468232  
E-mail : [contactusksbindia@ksb.com](mailto:contactusksbindia@ksb.com)  
[www.ksbindia.co.in](http://www.ksbindia.co.in)